

# Demonstration System EPC9057 Quick Start Guide

*EPC2039*

*80 V Half Bridge with Gate Drive*



## DESCRIPTION

The EPC9057 development board is a 80 V maximum device voltage, 6 A maximum output current, half bridge with onboard gate drives, featuring the EPC2039 enhancement mode (eGaN<sup>®</sup>) field effect transistor (FET). The purpose of this development board is to simplify the evaluation process of the EPC2039 eGaN FET by including all the critical components on a single board that can be easily connected into any existing converter.

The EPC9057 development board is 2" x 1.5" and contains not only two EPC2039 eGaN FET in a half bridge configuration using the Texas Instruments LM5113 gate driver, supply and bypass capacitors. The board contains all critical components and layout for optimal switching performance. There are also various probe points to facilitate simple waveform measurement and efficiency calculation. A complete block diagram of the circuit is given in Figure 1.

For more information on the EPC2039s eGaN FET please refer to the datasheet available from EPC at [www.epc-co.com](http://www.epc-co.com). The datasheet should be read in conjunction with this quick start guide.

## QUICK START GUIDE

Development board EPC9057 is easy to set up to evaluate the performance of the EPC2039 eGaN FET. Refer to Figure 2 for proper connect and measurement setup and follow the procedure below:

1. With power off, connect the input power supply bus to +V<sub>IN</sub> (J5, J6) and ground / return to -V<sub>IN</sub> (J7, J8).
2. With power off, connect the switch node of the half bridge OUT (J3, J4) to your circuit as required.
3. With power off, connect the gate drive input to +V<sub>DD</sub> (J1, Pin-1) and ground return to -V<sub>DD</sub> (J1, Pin-2).
4. With power off, connect the input PWM control signal to PWM (J2, Pin-1) and ground return to any of the remaining J2 pins.
5. Turn on the gate drive supply – make sure the supply is between 7 V and 12 V range.
6. Turn on the bus voltage to the required value (do not exceed the absolute maximum voltage of 80 V on V<sub>OUT</sub>).
7. Turn on the controller / PWM input source and probe switching node to see switching operation.
8. Once operational, adjust the bus voltage and load PWM control within the operating range and observe the output switching behavior, efficiency and other parameters.
9. For shutdown, please follow steps in reverse.

**NOTE.** When measuring the high frequency content switch node (OUT), care must be taken to avoid long ground leads. Measure the switch node (OUT) by placing the oscilloscope probe tip through the large via on the switch node (designed for this purpose) and grounding the probe directly across the GND terminals provided. See Figure 3 for proper scope probe technique.

Symbol	Parameter	Conditions	Min	Max	Units
V <sub>DD</sub>	Gate Drive Input Supply Range		7	12	V
V <sub>IN</sub>	Bus Input Voltage Range			60*	V
V <sub>OUT</sub>	Switch Node Output Voltage			80	V
I <sub>OUT</sub>	Switch Node Output Current			6*	A
V <sub>PWM</sub>	PWM Logic Input Voltage Threshold	Input 'High' Input 'Low'	3.5 0	6 1.5	V V
	Minimum 'High' State Input Pulse Width	V <sub>PWM</sub> rise and fall time < 10 ns	60		ns
	Minimum 'Low' State Input Pulse Width	V <sub>PWM</sub> rise and fall time < 10 ns	200#		ns

\*Assumes inductive load, maximum current depends on die temperature – actual maximum current will be subject to switching frequency, bus voltage and thermals.

# Limited by time needed to 'refresh' high side bootstrap supply voltage.

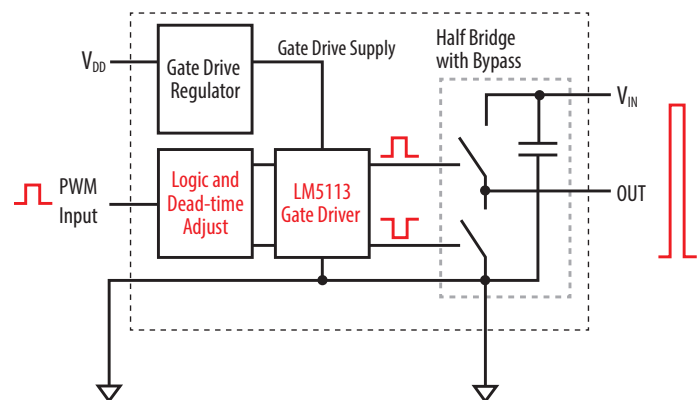

Figure 1: Block Diagram of EPC9057 Development Board

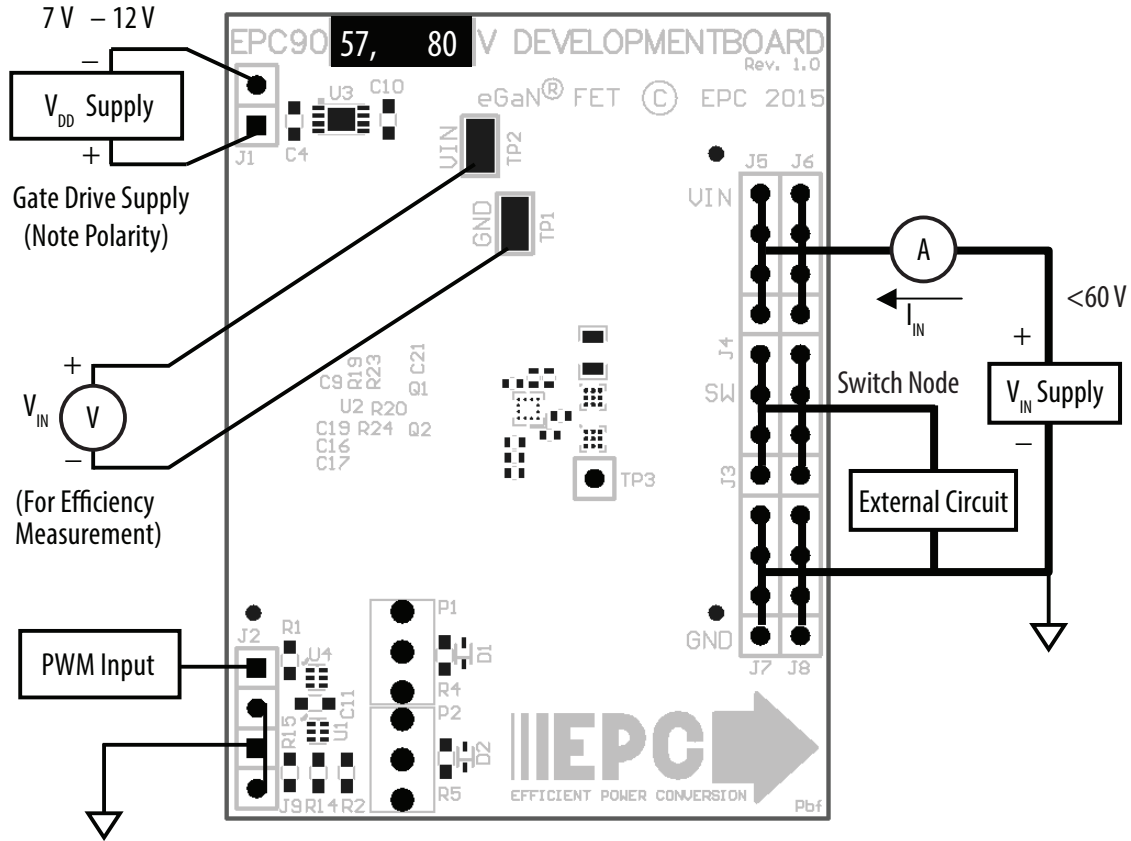

Figure 2: Proper Connection and Measurement Setup

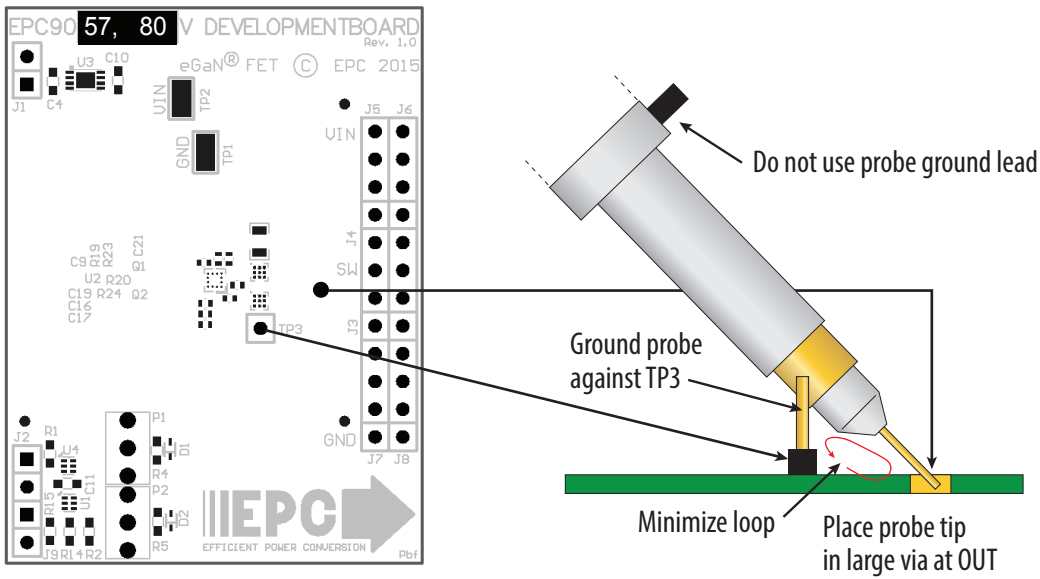

Figure 3: Proper Measurement of Switch Node –  $V_{SW}$

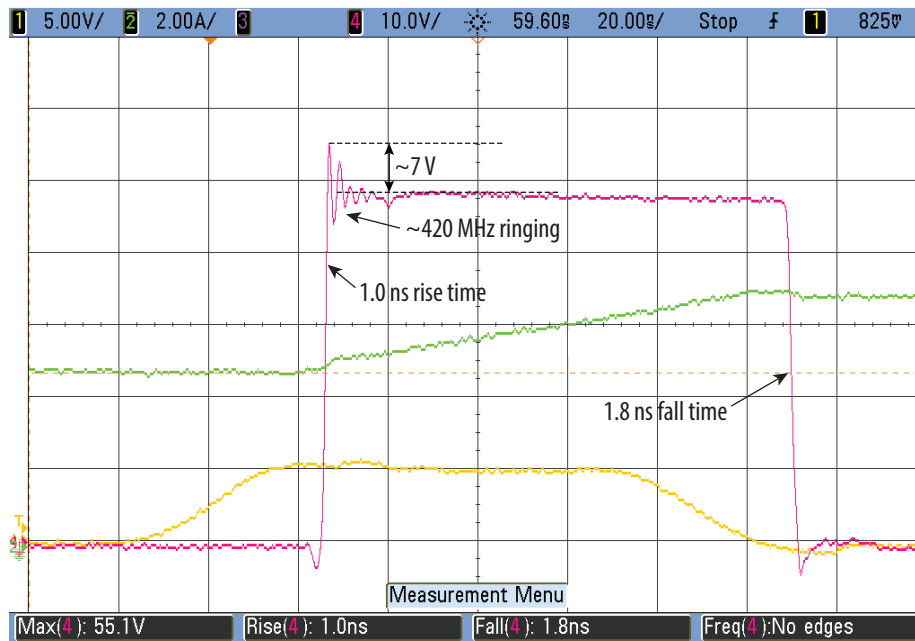

Figure 4: Typical Waveforms for  $V_{IN} = 48\text{ V}$  to  $2.5\text{ V}/6\text{ A}$  (500 kHz) Buck converter  
 CH1: Switch node voltage ( $V_{SW}$ ) - CH2: PWM input voltage ( $V_{PWM}$ )

### THERMAL CONSIDERATIONS

The EPC9057 development board showcases the EPC2039 eGaN FET. Although the electrical performance surpasses that for traditional Si devices, their relatively smaller size does magnify the thermal management requirements. The EPC9057 is intended for bench evaluation with low ambient temperature and convection cooling. The addition of heat-

sinking and forced air cooling can significantly increase the current rating of these devices, but care must be taken to not exceed the absolute maximum die temperature of 125°C.

**NOTE.** The EPC9057 development board does not have any current or thermal protection on board.

Table 2: Bill of Materials - Amplifier Board

Item	Qty	Reference	Part Description	Manufacturer	Part #
1	3	C4, C10, C11	Capacitor, 1 $\mu$ F, 10%, 25 V, X5R	Murata	GRM188R61E105KA12D
2	2	C16, C17	Capacitor, 100 pF, 5%, 50 V, NP0	Kemet	C0402C101K5GACTU
3	2	C9, C19	Capacitor, 0.1 $\mu$ F, 10%, 25 V, X5R	TDK	C1005X5R1E104K
4	3	C21, C22, C23	Capacitor, 1 $\mu$ F, 10%, 100 V, X7R	TDK	CGA4J3X752A105K125AE
5	2	D1, D2	Schottky Diode, 30 V	Diodes Inc.	SDM03U40-7
6	3	J1, J2, J9	Connector	2pins of Tyco	4-103185-0
7	1	J3, J4, J5, J6, J7, J8	Connector	FCI	68602-224HLF
8	2	Q1, Q2	eGaN <sup>®</sup> FET	EPC	EPC2039
9	1	R1	Resistor, 10.0 K, 5%, 1/8 W	Stackpole	RMCF0603FT10K0
10	2	R2, R15	Resistor, 0 $\Omega$ , 1/8 W	Stackpole	RMCF0603ZTOR00
11	1	R4	Resistor, 22 $\Omega$ , 1%, 1/8 W	Stackpole	RMCF0603FT22R0
12	1	R5	Resistor, 47 $\Omega$ , 1%, 1/8 W	Stackpole	RMCF0603FT47R0
13	4	R19, R20, R23, R24	Resistor, 1 $\Omega$ , 1/16 W	Stackpole	RMCF0402FT1R00
14	2	TP1, TP2	Test Point	Keystone Elect	5015
15	1	TP3	Connector	1/40th of Tyco	4-103185-0
16	1	U1	I.C., Logic	Fairchild	NC7SZ00L6X
17	1	U2	I.C., Gate driver	Texas Instruments	LM5113TME
18	1	U3	I.C., Regulator	Microchip	MCP1703T-5002E/MC
19	1	U4	I.C., Logic	Fairchild	NC7SZ08L6X
20	0	R14	Optional Resistor		
21	0	D3	Optional Diode		
22	0	P1, P2	Optional Potentiometer		

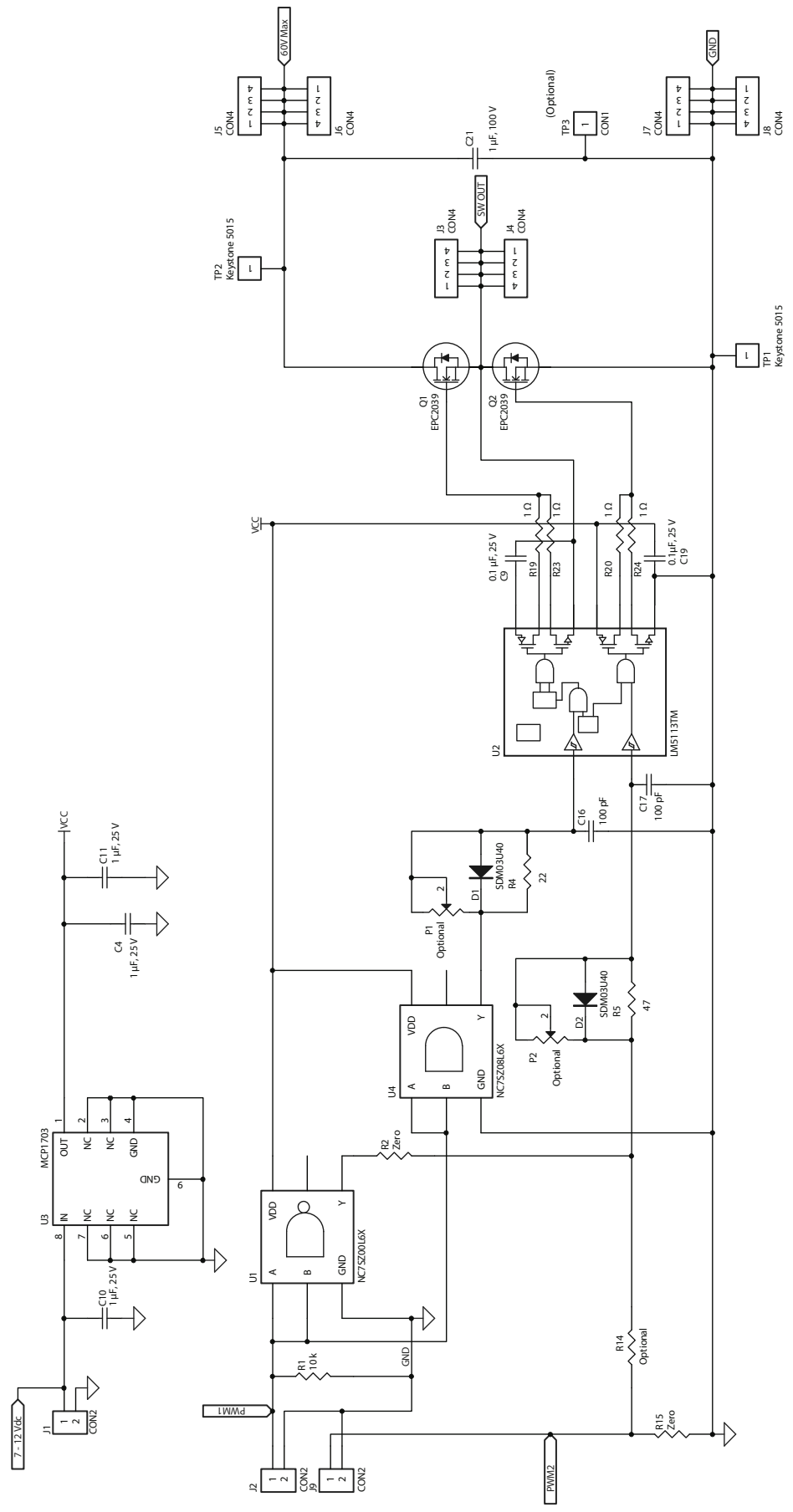

Figure 5: Development Board EPC9057 Schematic

## For More Information:

Please contact [info@epc-co.com](mailto:info@epc-co.com)  
or your local sales representative

Visit our website:

[www.epc-co.com](http://www.epc-co.com)

Sign-up to receive  
EPC updates at  
[bit.ly/EPCupdates](http://bit.ly/EPCupdates)  
or text "EPC" to 22828



EPC Products are distributed through Digi-Key.

[www.digikey.com](http://www.digikey.com)

### Demonstration Board Notification

The EPC9057 boards are intended for product evaluation purposes only and is not intended for commercial use. As an evaluation tool, it is not designed for compliance with the European Union directive on electromagnetic compatibility or any other such directives or regulations. As board builds are at times subject to product availability, it is possible that boards may contain components or assembly materials that are not RoHS compliant. Efficient Power Conversion Corporation (EPC) makes no guarantee that the purchased board is 100% RoHS compliant. No Licenses are implied or granted under any patent right or other intellectual property whatsoever. EPC assumes no liability for applications assistance, customer product design, software performance, or infringement of patents or any other intellectual property rights of any kind.

EPC reserves the right at any time, without notice, to change said circuitry and specifications.